



6W CW 808nm VCSEL Array C-mount Part # PCW-CD-6-W0808

- Vertical-Cavity Surface-Emitting Laser technology
- Very high reliability, can operate at high temperatures (up to 80 °C)
- Wavelength stabilized & narrow spectral width (<1nm)
- Easily soldered to heat exchanger

Optical & Electrical Characteristics

PARAMETER	CONDITIONS	MIN	TYP	MAX	UNIT
CW Output Power	10A, 20C Heat-sink	6	8	--	W
Threshold current	20C Heat-sink	--	1	3	A
Operating current	6W, 20C Heat-sink	--	7	9	A
Operating voltage	6W, 20C Heat-sink	--	2.1	2.5	V
Differential resistance	6W, 20C Heat-sink	--	80	100	mΩ
Slope efficiency	20C Heat-sink	1	1.1	--	W/A
Conversion efficiency	6W, 20C Heat-sink	35	44	--	%
Center wavelength	6W, 20C Heat-sink	800	808	816	nm
Spectral width (FWHM)	6W, 20C Heat-sink	--	0.8	1.5	nm
Wavelength shift	20C Heat-sink	--	--	0.070	nm/°C
N.A. (4-sigma)	6W, 20C Heat-sink	--	0.15	0.17	--
Emission area	--	--	1.5x1.5	--	mm ²

Maximum Absolute Ratings

PARAMETER	CONDITIONS
Forward current	50A
Reverse current	25μA
Operating temperature	0 to +80 °C
Storage temperature	-40 to +80 °C

Ordering information

PCW - CD - 6 - W0808

Package type _____ Wavelength (nm) _____
 _____ CW Output Power (W) _____

Princeton Optronics, Inc. * 1 Electronics Drive * Mercerville, New Jersey 08619

Voice: (609) 584-9696 * Fax: (609) 584-2448 * E-mail: sales@princetonoptronics.com * www.princetonoptronics.com

Mechanical Characteristics

PARAMETER	VALUE
Package width	8.9 +/-0.1 mm
Package length	17.8 +/-0.1 mm
Package height	3.0 +/-0.1 mm
Light emitting area	1.5mm x 1.5mm
Max solder temperature	118 °C

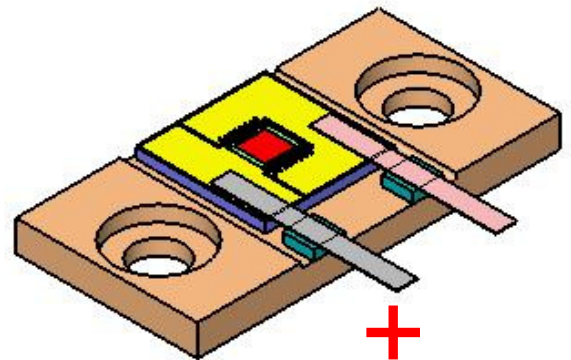
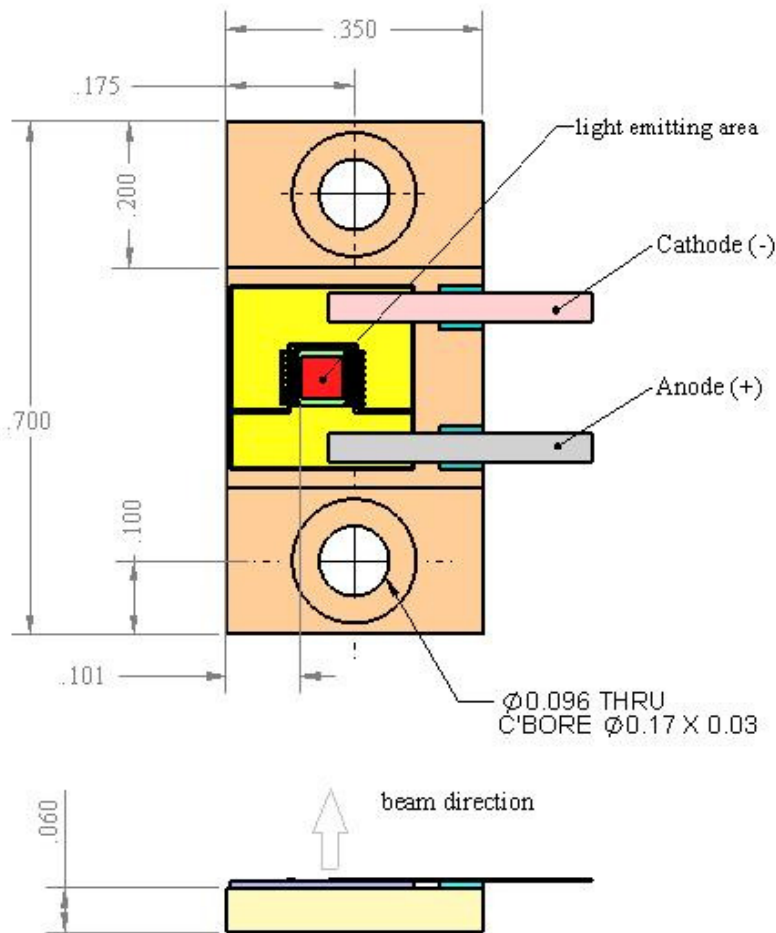

Copyright © 2010 Princeton Optronics, Inc.
All Rights Reserved.

Princeton Optronics reserves the right to change product design and specifications at any time without notice.

No license is granted by implication or otherwise under any patents or patent right of Princeton Optronics. No responsibility is assumed for the use of these products, nor for any infringement on the rights of others resulting from the use of these products

Laser diode product components are intended for use in a user-devised end system. However, these products are capable of emitting Class IV radiation. Extreme care must be exercised during their operation. Only persons familiar with the appropriate safety precautions should operate a laser product. Directly viewing the laser beam or exposure to specular reflections must be avoided. Serious injury may result if any part of the body is exposed to the beam. The eye is extremely sensitive to the infrared radiation and therefore, proper eye-wear must be worn at all times. Use of optical instruments with these products may increase eye hazard. Always wear eye protection when operating.

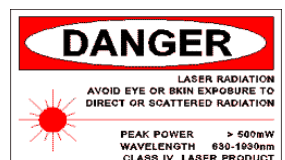

REV. B - 01/10

Princeton Optronics, Inc. * 1 Electronics Drive * Mercerville, New Jersey 08619

Voice: (609) 584-9696 * Fax: (609) 584-2448 * E-mail: sales@princetonoptronics.com * www.princetonoptronics.com