



100W CW 975nm VCSEL Array on Micro-Channel-Cooler Part # PCW-CS1-100-W0975-MC

- Vertical-Cavity Surface-Emitting Laser technology
- Very high reliability, can operate at high temperatures (up to 80 °C)
- Low thermal resistance (~0.16 °C/W)
- Wavelength stabilized & Narrow spectral width (<1nm)
- Mounted on micro-channel-cooler
- Custom wavelengths available (808-1064nm)

Optical & Electrical Characteristics

PARAMETER	CONDITIONS	MIN	TYP	MAX	UNIT
CW Output Power	135A, 25C Heat-sink	100	110	--	W
Threshold current	25C Heat-sink	--	16	20	A
Operating current	100W, 25C Heat-sink	--	125	135	A
Operating voltage	100W, 25C Heat-sink	--	2.1	2.5	V
Differential resistance	100W, 25C Heat-sink	--	5.8	7.0	mΩ
Slope efficiency	25C Heat-sink	0.85	0.95	--	W/A
Conversion efficiency	55W, 25C Heat-sink	40	43	--	%
Center wavelength	100W, 25C Heat-sink	965	975	985	nm
Spectral width (FWHM)	100W, 25C Heat-sink	--	0.8	1	nm
Wavelength shift	25C Heat-sink	0.060	0.065	0.070	nm/°C
N.A. (4-sigma)	100W, 25C Heat-sink	--	0.15	0.17	--
Emission area	--	--	4.7x4.7	--	mm ²

Maximum Absolute Ratings

PARAMETER	CONDITIONS
Forward current	280A
Reverse current	25μA
Operating temperature	0 to +80 °C
Storage temperature	-40 to +80 °C

Ordering information

PCW - CS1 - 100 - W0975-MC

Package type _____ Wavelength (nm)
 _____ CW Output Power (W)

Princeton Optronics, Inc. * 1 Electronics Drive * Mercerville, New Jersey 08619

Voice: (609) 584-9696 * Fax: (609) 584-2448 * E-mail: sales@princetonoptronics.com * www.princetonoptronics.com

Mechanical Characteristics

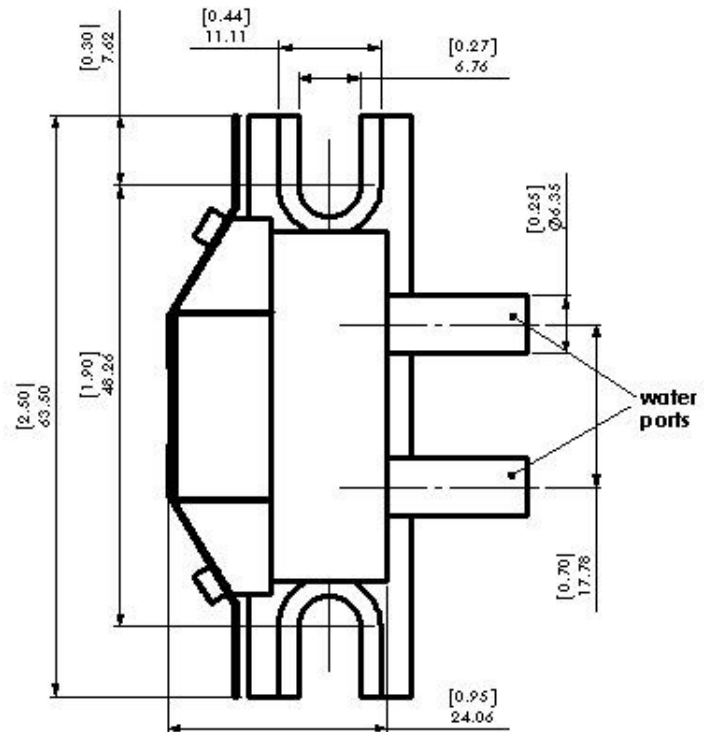
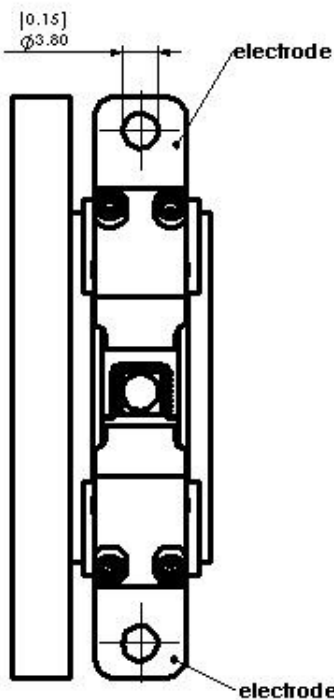
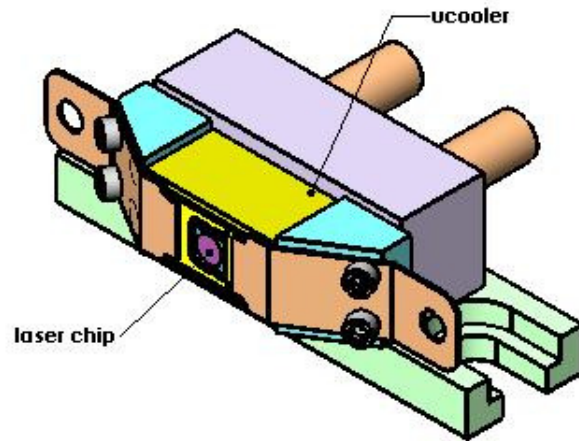
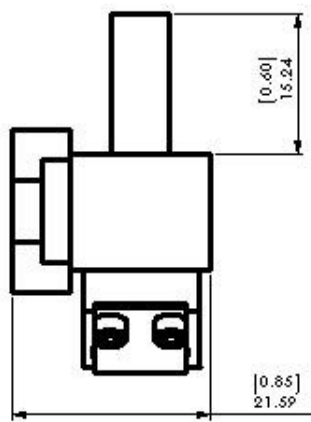

Copyright © 2009 Princeton Optronics, Inc.
All Rights Reserved.

Princeton Optronics reserves the right to change product design and specifications at any time without notice.

No license is granted by implication or otherwise under any patents or patent right of Princeton Optronics. No responsibility is assumed for the use of these products, nor for any infringement on the rights of others resulting from the use of these products

Laser diode product components are intended for use in a user-devised end system. However, these products are capable of emitting Class IV radiation. Extreme care must be exercised during their operation. Only persons familiar with the appropriate safety precautions should operate a laser product. Directly viewing the laser beam or exposure to specular reflections must be avoided. Serious injury may result if any part of the body is exposed to the beam. The eye is extremely sensitive to the infrared radiation and therefore, proper eye-wear must be worn at all times. Use of optical instruments with these products may increase eye hazard. Always wear eye protection when operating.

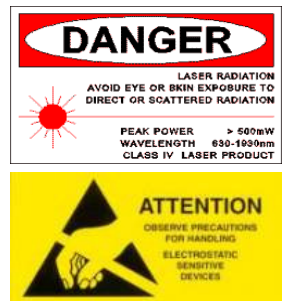

REV. A – 08/09

Princeton Optronics, Inc. * 1 Electronics Drive * Mercerville, New Jersey 08619

Voice: (609) 584-9696 * Fax: (609) 584-2448 * E-mail: sales@princetonoptronics.com * www.princetonoptronics.com