

## HIGH POWER LASER ILLUMINATOR PART # PR-HPIL-3W808-OHD

### KEY FEATURES

- *Speckle/Fringe Free Uniform Illumination*
- *High Power Output >3W (Equivalent to 2,000 Lumens)*
- *Circular Beam*
- *Random Polarization*
- *2D Matrix of Light Emitters*
- *Beam Divergence: 20° (Full Angle at 1/e<sup>2</sup>)*
- *Center Wavelength: 808nm, 976nm*
- *Narrow Wavelength Spread (<3nm FWHM)*
- *Operating Temperature: -20 to 40°C (Environment)*
- *Wavelength Drift with Temperature: 0.06nm/°C*
- *Vertical-Cavity Surface-Emitting Laser technology*

### Ordering information

**PR-HPIL- 3W808 - OHD**

CW Output Power (W) \_\_\_\_\_ Package Type \_\_\_\_\_  
Wavelength (nm) \_\_\_\_\_

Princeton Optronics, Inc. \* 1 Electronics Drive \* Mercerville, New Jersey 08619

Voice: (609) 584-9696 \* Fax: (609) 584-2448 \* E-mail: sales@princetonoptronics.com \* www.princetonoptronics.com

## Optical & Electrical Characteristics

PARAMETER	CONDITIONS	MIN	TYP	MAX	UNIT
CW Output Power	1A, 20C Heat-sink	3	4	--	W
Threshold current	20C Heat-sink	--	0.15	0.2	A
Operating current	3W, 20C Heat-sink	--	0.75	0.9	A
Operating voltage	3W, 20C Heat-sink	--	10	11	V
Differential resistance	3W, 20C Heat-sink	--	1.5	2	$\Omega$
Slope efficiency	20C Heat-sink	--	5	--	W/A
Conversion efficiency	3W, 20C Heat-sink	35	40	--	%
Threshold current	50C Heat-sink	--	0.2	0.25	A
Operating current	3W, 50C Heat-sink	--	0.85	1	A
Operating voltage	3W, 50C Heat-sink	--	10.7	11.2	V
Slope efficiency	50C Heat-sink	--	4.6	--	W/A
Conversion efficiency	3W, 50C Heat-sink	30	33	--	%

### Package Type - OHD

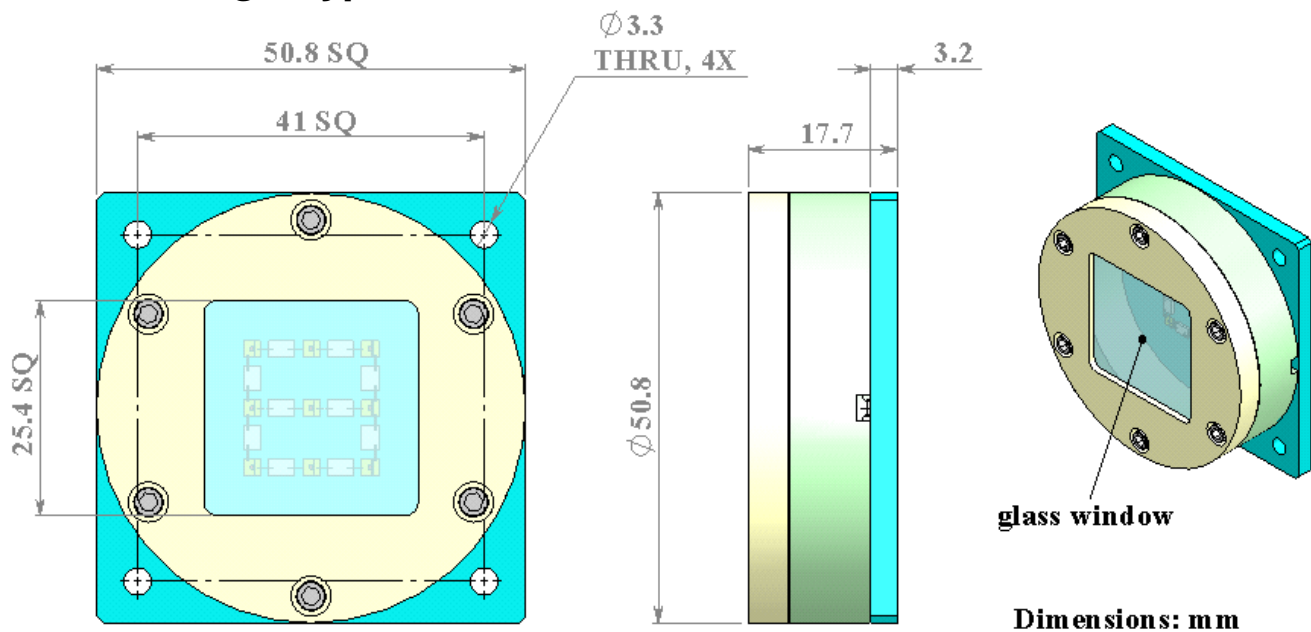

Princeton Optronics, Inc. \* 1 Electronics Drive \* Mercerville, New Jersey 08619

Voice: (609) 584-9696 \* Fax: (609) 584-2448 \* E-mail: sales@princetonoptronics.com \* www.princetonoptronics.com

## Package Type - HSF

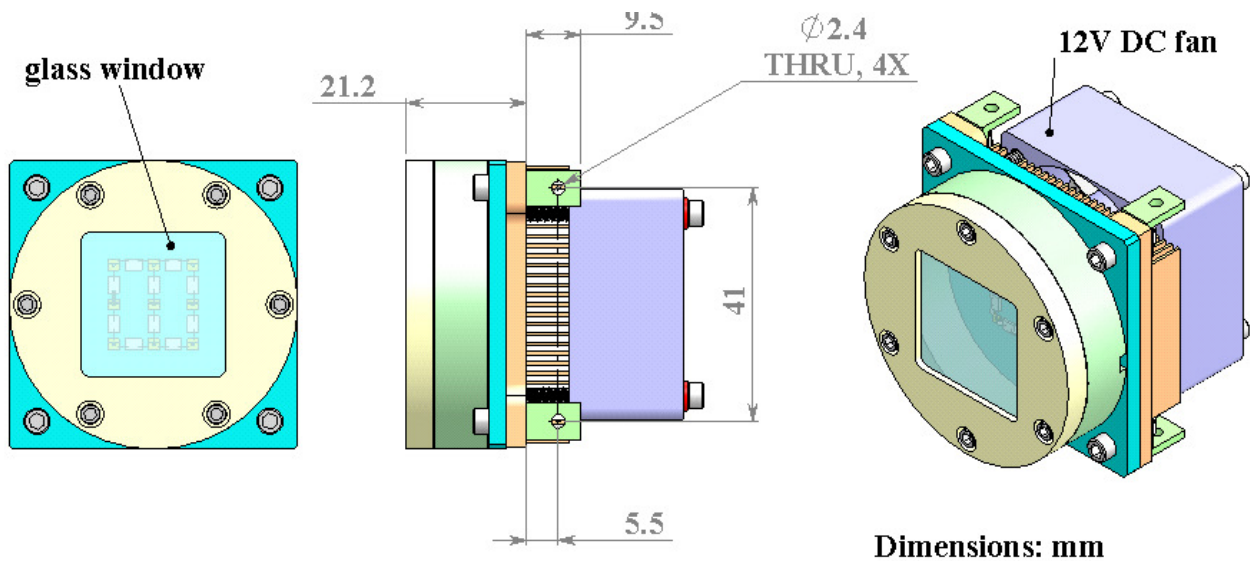

## Package Type – MDL (call for specs)

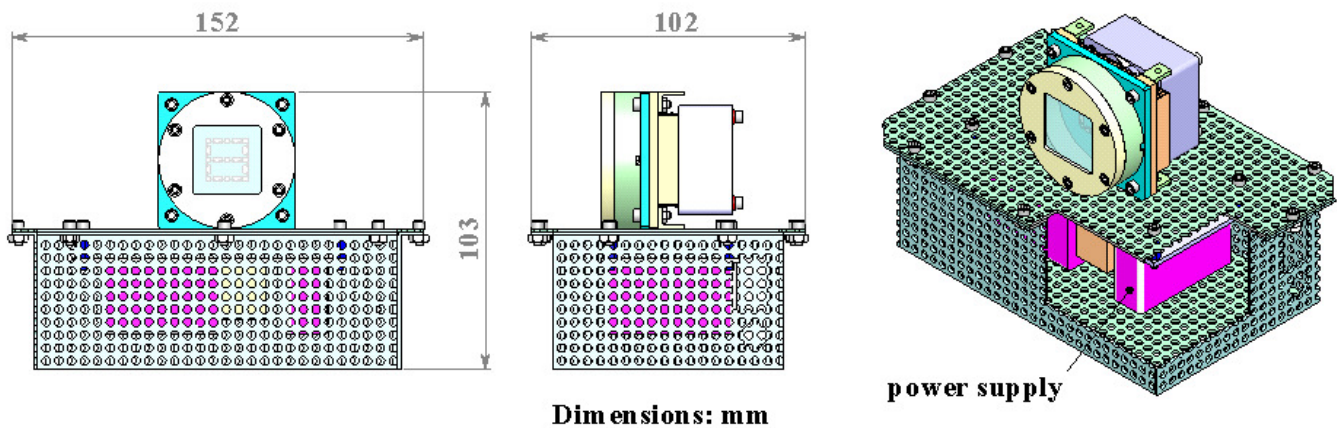

Copyright © 2010 Princeton Optronics, Inc.  
All Rights Reserved.

Princeton Optronics reserves the right to change product design and specifications at any time without notice.

No license is granted by implication or otherwise under any patents or patent right of Princeton Optronics. No responsibility is assumed for the use of these products, nor for any infringement on the rights of others resulting from the use of these products

Laser diode product components are intended for use in a user-devised end system. However, these products are capable of emitting Class IV radiation. Extreme care must be exercised during their operation. Only persons familiar with the appropriate safety precautions should operate a laser product. Directly viewing the laser beam or exposure to specular reflections must be avoided. Serious injury may result if any part of the body is exposed to the beam. The eye is extremely sensitive to the infrared radiation and therefore, proper eye-wear must be worn at all times. Use of optical instruments with these products may increase eye hazard. Always wear eye protection when operating.

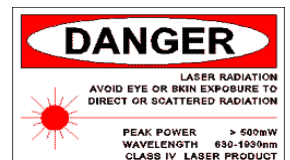

REV. B – 01/10

Princeton Optronics, Inc. \* 1 Electronics Drive \* Mercerville, New Jersey 08619

Voice: (609) 584-9696 \* Fax: (609) 584-2448 \* E-mail: sales@princetonoptronics.com \* www.princetonoptronics.com